

BS10

Flanges

ASHBY SCOTT

PIPE SYSTEMS



TABLE D

Plate Slip-On Flanges

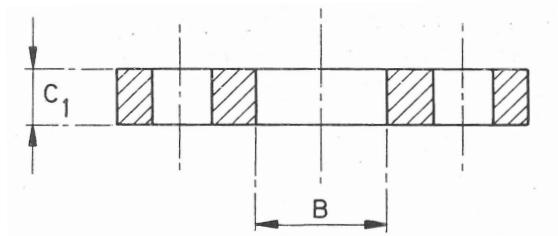

Nominal Size	Pipe OD	Outside Diameter	Bolt Circle Diameter	Bolt Hole Diameter	Bolting		Flange Thickness Min
	MM	MM	MM	MM	No.	Size (MM)	MM
1/2	21.3	95.3	66.7	14	4	M12	12.7
3/4	26.9	101.6	73.0	14	4	M12	12.7
1	33.7	114.3	82.6	14	4	M12	12.7
1 1/4	42.5	120.7	87.3	14	4	M12	12.7
1 1/2	48.3	133.4	98.4	14	4	M12	12.7
2	60.3	152.4	114.3	18	4	M16	12.7
2 1/2	76.1	165.1	127.0	18	4	M16	12.7
3	88.9	184.2	146.1	18	4	M16	12.7
4	114.3	215.9	177.8	18	4	M16	12.7
5	139.7	254.0	209.6	18	8	M16	12.7
6 1/2	165.1	279.4	235.0	18	8	M16	12.7
6 5/8	168.3	279.4	235.0	18	8	M16	12.7
8	211.1	336.6	292.1	18	8	M16	12.7
10	273.0	406.4	355.6	22	8	M20	16.0
12	323.9	457.2	406.4	22	12	M20	20.0
14	355.6	527.1	469.9	24	12	M22	22.2
16	406.4	577.9	520.7	24	12	M22	22.2
18	457.0	641.4	584.2	24	12	M22	25.4
20	508.0	704.9	641.4	26	16	M22	28.6
24	610.0	825.5	755.7	26	16	M24	31.8

TABLE D

Plate Blind Flanges

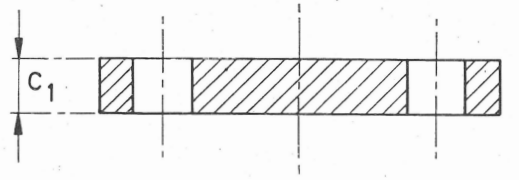

Nominal Size	Pipe OD	Outside Diameter	Bolt Circle Diameter	Bolt Hole Diameter	Bolting		Flange Thickness Min
	MM	MM	MM	MM	No.	Size (MM)	MM
1/2	21.3	95.3	66.7	14	4	M12	12.7
3/4	26.9	101.6	73.0	14	4	M12	12.7
1	33.7	114.3	82.6	14	4	M12	12.7
1 1/4	42.5	120.7	87.3	14	4	M12	12.7
1 1/2	48.3	133.4	98.4	14	4	M12	12.7
2	60.3	152.4	114.3	18	4	M16	12.7
2 1/2	76.1	165.1	127.0	18	4	M16	12.7
3	88.9	184.2	146.1	18	4	M16	12.7
4	114.3	215.9	177.8	18	4	M16	12.7
5	139.7	254.0	209.6	18	8	M16	12.7
6 1/2	165.1	279.4	235.0	18	8	M16	12.7
6 5/8	168.3	279.4	235.0	18	8	M16	12.7
8	211.1	336.6	292.1	18	8	M16	12.7
10	273.0	406.4	355.6	22	8	M20	16.0
12	323.9	457.2	406.4	22	12	M20	20.0
14	355.6	527.1	469.9	24	12	M22	22.2
16	406.4	577.9	520.7	24	12	M22	22.2
18	457.0	641.4	584.2	24	12	M22	25.4
20	508.0	704.9	641.4	26	16	M22	28.6
24	610.0	825.5	755.7	26	16	M24	31.8

TABLE D

Bossed Slip-On Flanges

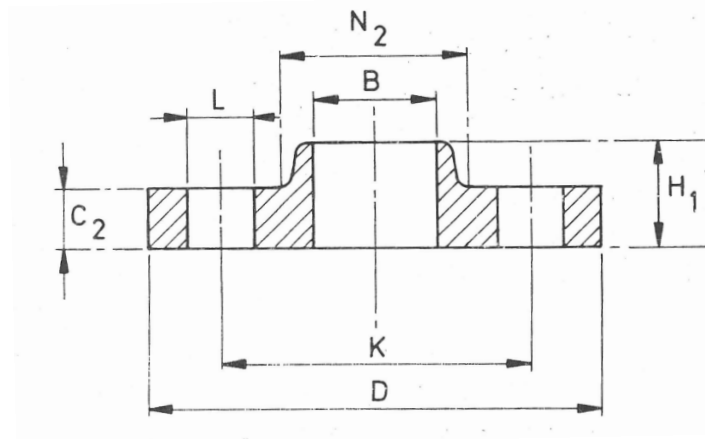

Nominal Size	Pipe OD	Outside Diameter	Bolt Circle Diameter	Bolt Hole Diameter	Bolting		Bore Diameter	Flange Thickness Min	Boss Diameter	Boss Diameter	Boss Height
	MM	MM	MM	MM	No.	Size (MM)	MM	MM	Large End Max. (MM)	Small End (MM)	MM
1/2	21.3	95.3	66.7	14	4	M12	22.0	12.7	38.1	33.3	9.5
3/4	26.9	101.6	73.0	14	4	M12	27.5	12.7	44.5	38.1	11.1
1	33.7	114.3	82.6	14	4	M12	34.5	12.7	52.4	47.6	11.1
1 1/4	42.5	120.7	87.3	14	4	M12	43.5	12.7	57.9	55.6	11.1
1 1/2	48.3	133.4	98.4	14	4	M12	49.5	12.7	69.9	61.9	12.7
2	60.3	152.4	114.3	18	4	M16	61.5	12.7	79.4	74.6	12.7
2 1/2	76.1	165.1	127.0	18	4	M16	77.5	12.7	92.9	90.5	15.9
3	88.9	184.2	146.1	18	4	M16	90.5	12.7	111.9	106.4	15.9
4	114.3	215.9	177.8	18	4	M16	116.0	12.7	139.7	133.4	19.1
5	139.7	254.0	209.6	18	8	M16	141.5	12.7	171.4	160.4	19.1
6 1/2	165.1	279.4	235.0	18	8	M16	167.3	12.7	196.8	185.7	19.1
6 5/8	168.3	279.4	235.0	18	8	M16	170.5	12.7	196.8	185.7	19.1
8	211.1	336.6	292.1	18	8	M16	221.5	12.7	254.0	241.3	22.2
10	273.0	406.4	355.6	22	8	M20	276.5	16.0	309.6	298.5	27.0
12	323.9	457.2	406.4	22	12	M20	327.5	20.0	360.4	349.3	28.6

TABLE D

Bossed Screwed Flanges

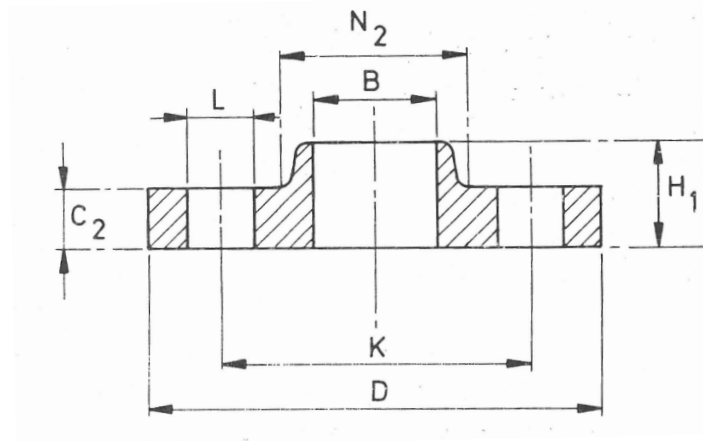

Nominal Size	Pipe OD	Outside Diameter	Bolt Circle Diameter	Bolt Hole Diameter	Bolting		Flange Thickness Min	Boss Diameter	Boss Diameter	Boss Height
	MM	MM	MM	MM	No.	Size (MM)	MM	Large End Max. (MM)	Small End (MM)	MM
1/2	21.3	95.3	66.7	14	4	M12	12.7	38.1	33.3	9.5
3/4	26.9	101.6	73.0	14	4	M12	12.7	44.5	38.1	11.1
1	33.7	114.3	82.6	14	4	M12	12.7	52.4	47.6	11.1
1 1/4	42.5	120.7	87.3	14	4	M12	12.7	57.9	55.6	11.1
1 1/2	48.3	133.4	98.4	14	4	M12	12.7	69.9	61.9	12.7
2	60.3	152.4	114.3	18	4	M16	12.7	79.4	74.6	12.7
2 1/2	76.1	165.1	127.0	18	4	M16	12.7	92.9	90.5	15.9
3	88.9	184.2	146.1	18	4	M16	12.7	111.9	106.4	15.9
4	114.3	215.9	177.8	18	4	M16	12.7	139.7	133.4	19.1
5	139.7	254.0	209.6	18	8	M16	12.7	171.4	160.4	19.1
6	165.1	279.4	235.0	18	8	M16	12.7	196.8	185.7	19.1

TABLE E

Plate Slip-On Flanges

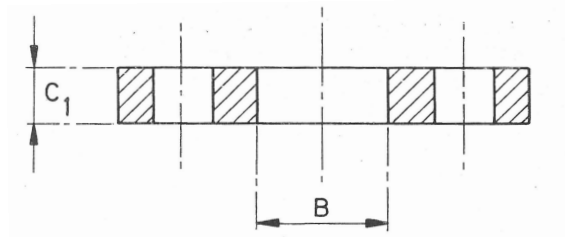

Nominal Size	Pipe OD	Outside Diameter	Bolt Circle Diameter	Bolt Hole Diameter	Bolting		Bore Diameter	Flange Thickness Min
	MM	MM	MM	MM	No.	Size (MM)	MM	MM
1/2	21.3	95.3	66.7	14	4	M12	22.0	12.7
3/4	26.9	101.6	73.0	14	4	M12	27.5	12.7
1	33.7	114.3	82.6	14	4	M12	34.5	12.7
1 1/4	42.5	120.7	87.3	14	4	M12	43.5	12.7
1 1/2	48.3	133.4	98.4	14	4	M12	49.5	12.7
2	60.3	152.4	114.3	18	4	M16	61.5	12.7
2 1/2	76.1	165.1	127.0	18	4	M16	77.5	12.7
3	88.9	184.2	146.1	18	4	M16	90.5	12.7
4	114.3	215.9	177.8	18	4	M16	116.0	12.7
5	139.7	254.0	209.6	18	8	M16	141.5	14.3
6 1/2	165.1	279.4	235.0	18	8	M16	167.3	17.5
6 5/8	168.3	279.4	235.0	22	8	M20	170.5	17.5
8	219.1	336.6	292.1	22	8	M20	221.5	19.1
10	273.0	406.4	355.6	22	12	M20	276.5	22.2
12	323.9	457.2	406.4	24	12	M22	327.5	25.4
14	355.6	527.1	469.9	24	12	M22	359.5	28.6
16	406.4	577.9	520.7	24	12	M22	411.0	31.8
18	457.0	641.4	584.2	24	16	M22	462.0	34.9
20	508.0	704.9	641.4	24	16	M22	513.5	38.1
24	610.0	825.5	755.7	30	16	M27	616.5	47.6

TABLE E

Plate Blind Flanges

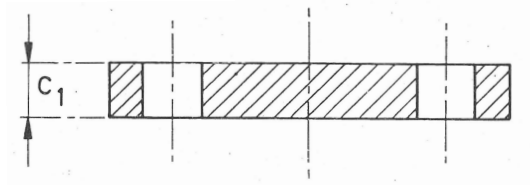

Nominal Size	Pipe OD	Outside Diameter	Bolt Circle Diameter	Bolt Hole Diameter	Bolting		Flange Thickness Min
	MM	MM	MM	MM	No.	Size (MM)	MM
1/2	21.3	95.3	66.7	14	4	M12	12.7
3/4	26.9	101.6	73.0	14	4	M12	12.7
1	33.7	114.3	82.6	14	4	M12	12.7
1 1/4	42.5	120.7	87.3	14	4	M12	12.7
1 1/2	48.3	133.4	98.4	14	4	M12	12.7
2	60.3	152.4	114.3	18	4	M16	12.7
2 1/2	76.1	165.1	127.0	18	4	M16	12.7
3	88.9	184.2	146.1	18	4	M16	12.7
4	114.3	215.9	177.8	18	4	M16	12.7
5	139.7	254.0	209.6	18	8	M16	14.3
6 1/2	165.1	279.4	235.0	18	8	M16	17.5
6 5/8	168.3	279.4	235.0	22	8	M20	17.5
8	219.1	336.6	292.1	22	8	M20	19.1
10	273.0	406.4	355.6	22	12	M20	22.2
12	323.9	457.2	406.4	24	12	M22	25.4
14	355.6	527.1	469.9	24	12	M22	28.6
16	406.4	577.9	520.7	24	12	M22	31.8
18	457.0	641.4	584.2	24	16	M22	34.9
20	508.0	704.9	641.4	24	16	M22	38.1
24	610.0	825.5	755.7	30	16	M27	47.6

TABLE E

Bossed Slip-On Flanges

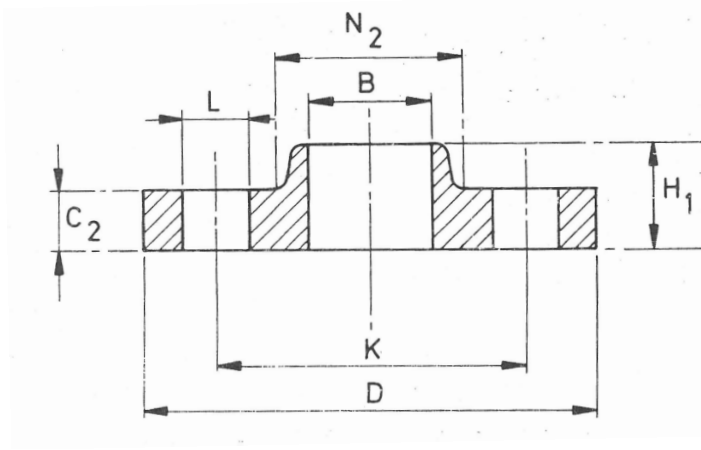

Nominal Size	Pipe OD	Outside Diameter	Bolt Circle Diameter	Bolt Hole Diameter	Bolting		Bore Diameter	Flange Thickness Min	Boss Diameter	Boss Diameter	Boss Height
	MM	MM	MM	MM	No.	Size (MM)	MM	MM	Large End Max. (MM)	Small End (MM)	MM
1/2	21.3	95.3	66.7	14	4	M12	22.0	12.7	38.1	33.3	9.5
3/4	26.9	101.6	73.0	14	4	M12	27.5	12.7	44.5	38.1	11.1
1	33.7	114.3	82.6	14	4	M12	34.5	12.7	52.4	47.6	11.1
1 1/4	42.5	120.7	87.3	14	4	M12	43.5	12.7	57.9	55.6	11.1
1 1/2	48.3	133.4	98.4	14	4	M12	49.5	12.7	69.9	61.9	12.7
2	60.3	152.4	114.3	18	4	M16	61.5	12.7	79.4	74.6	12.7
2 1/2	76.1	165.1	127.0	18	4	M16	77.5	12.7	92.9	90.5	15.9
3	88.9	184.2	146.1	18	4	M16	90.5	12.7	111.9	106.4	15.9
4	114.3	215.9	177.8	18	4	M16	116.0	12.7	139.7	133.4	19.0
5	139.7	254.0	209.6	18	8	M16	141.5	14.3	171.4	160.3	19.0
6 1/2	165.1	279.4	235.0	18	8	M16	167.3	17.5	190.5	185.7	19.0
6 5/8	168.3	279.4	235.0	22	8	M20	170.5	17.5	190.5	185.7	19.0
8	219.1	336.6	292.1	22	8	M20	221.5	19.1	233.4	241.3	22.2
10	273.0	406.4	355.6	22	12	M20	276.5	22.2	309.6	298.5	27.0
12	323.9	457.2	406.4	24	12	M22	327.5	25.4	354.0	349.3	28.6

TABLE E

Bossed Screwed Flanges

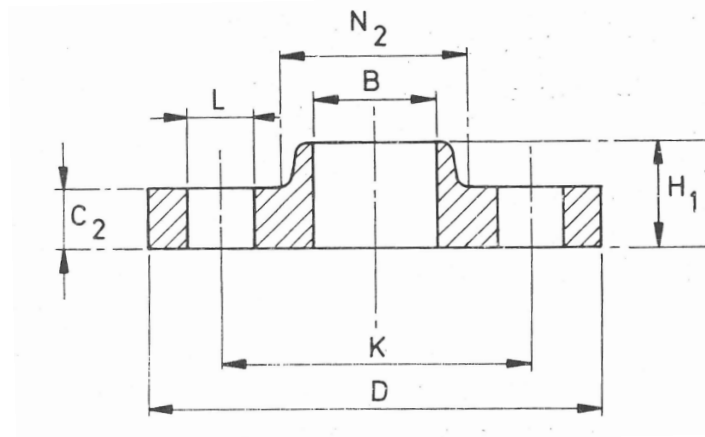

Nominal Size	Pipe OD	Outside Diameter	Bolt Circle Diameter	Bolt Hole Diameter	Bolting		Flange Thickness Min	Boss Diameter	Boss Diameter	Boss Height
	MM	MM	MM	MM	No.	Size (MM)	MM	Large End Max. (MM)	Small End (MM)	MM
1/2	21.3	95.3	66.7	14	4	M12	12.7	38.1	33.3	9.5
3/4	26.9	101.6	73.0	14	4	M12	12.7	44.5	38.1	11.1
1	33.7	114.3	82.6	14	4	M12	12.7	52.4	47.6	11.1
1 1/4	42.5	120.7	87.3	14	4	M12	12.7	57.9	55.6	11.1
1 1/2	48.3	133.4	98.4	14	4	M12	12.7	69.9	61.9	12.7
2	60.3	152.4	114.3	18	4	M16	12.7	79.4	74.6	12.7
2 1/2	76.1	165.1	127.0	18	4	M16	12.7	92.9	90.5	15.9
3	88.9	184.2	146.1	18	4	M16	12.7	111.9	106.4	15.9
4	114.3	215.9	177.8	18	4	M16	12.7	139.7	133.4	19.0
5	139.7	254.0	209.6	18	8	M16	14.3	171.4	160.3	19.0
6 1/2	165.1	279.4	235.0	18	8	M20	17.5	190.5	185.7	19.0
6 5/8	168.3	279.4	235.0	22	8	M20	17.5	190.5	185.7	19.0

TABLE F

Slip-On Flanges

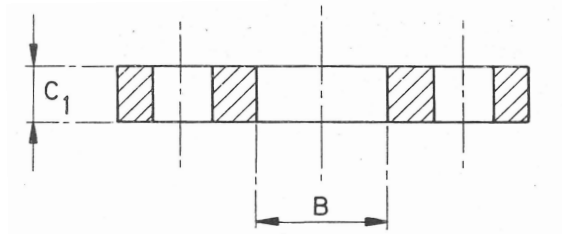

Nominal Size	Pipe OD	Outside Diameter	Bolt Circle Diameter	Bolt Hole Diameter	Bolting		Flange Thickness Min
	MM	MM	MM	MM	No.	Size (MM)	MM
1/2	21.3	95.3	66.7	14	4	M12	12.7
3/4	26.9	101.6	73.0	14	4	M12	12.7
1	33.7	120.7	87.3	18	4	M16	12.7
1 1/4	42.5	133.4	98.4	18	4	M16	12.7
1 1/2	48.3	139.7	104.8	18	4	M16	12.7
2	60.3	165.4	127.0	18	4	M16	15.9
2 1/2	76.1	184.2	146.1	18	8	M16	15.9
3	88.9	203.2	165.1	18	8	M16	15.9
4	114.3	228.6	190.5	18	8	M16	19.1
5	139.7	279.4	235.0	22	8	M20	22.2
6 1/2	165.1	304.8	260.4	22	12	M20	22.2
6 5/8	168.3	304.8	260.4	22	12	M20	22.2
8	219.1	368.3	323.9	22	12	M20	25.4
10	273.0	431.8	381.0	25	12	M22	28.6
12	323.9	489.0	438.2	25	16	M22	31.8
14	355.6	552.5	495.3	26	16	M24	34.9
16	406.4	609.6	552.5	26	20	M24	41.3
18	457.0	673.1	609.6	30	20	M27	44.5
20	508.0	736.6	673.1	0	24	M27	50.8
24	610.0	850.9	781.1	33	24	M30	57.2

TABLE F

Plate Blind Flanges

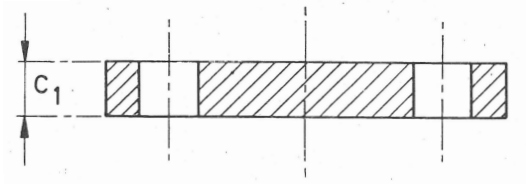

Nominal Size	Pipe OD	Outside Diameter	Bolt Circle Diameter	Bolt Hole Diameter	Bolting		Flange Thickness Min
	MM	MM	MM	MM	No.	Size (MM)	MM
1/2	21.3	95.3	66.7	14	4	M12	12.7
3/4	26.9	101.6	73.0	14	4	M12	12.7
1	33.7	120.7	87.3	18	4	M16	12.7
1 1/4	42.5	133.4	98.4	18	4	M16	12.7
1 1/2	48.3	139.7	104.8	18	4	M16	12.7
2	60.3	165.4	127.0	18	4	M16	15.9
2 1/2	76.1	184.2	146.1	18	8	M16	15.9
3	88.9	203.2	165.1	18	8	M16	15.9
4	114.3	228.6	190.5	18	8	M16	19.1
5	139.7	279.4	235.0	22	8	M20	22.2
6 1/2	165.1	304.8	260.4	22	12	M20	22.2
6 5/8	168.3	304.8	260.4	22	12	M20	22.2
8	219.1	368.3	323.9	22	12	M20	25.4
10	273.0	431.8	381.0	25	12	M22	28.6
12	323.9	489.0	438.2	25	16	M22	31.8
14	355.6	552.5	495.3	26	16	M24	34.9
16	406.4	609.6	552.5	26	20	M24	41.3
18	457.0	673.1	609.6	30	20	M27	44.5
20	508.0	736.6	673.1	0	24	M27	50.8
24	610.0	850.9	781.1	33	24	M30	57.2

TABLE F

Bossed Slip-On Flanges

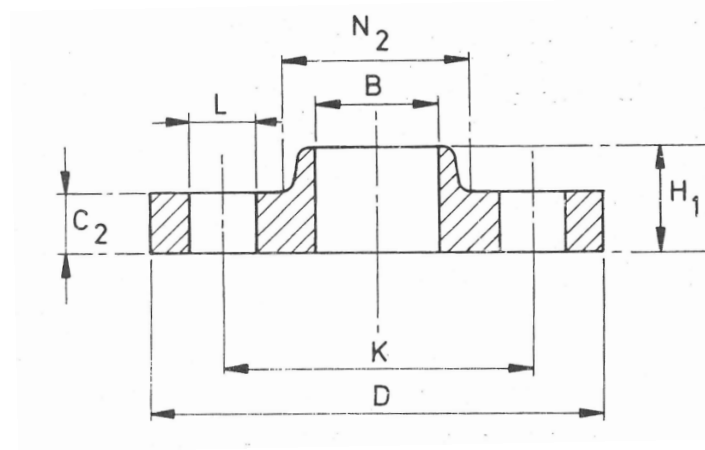

Nominal Size	Pipe OD	Outside Diameter	Bolt Circle Diameter	Bolt Hole Diameter	Bolting		Bore Diameter	Flange Thickness Min	Boss Diameter	Boss Diameter	Boss Height
	MM	MM	MM	MM	No.	Size (MM)	MM	MM	Large End Max. (MM)	Small End (MM)	MM
1/2	21.3	95.3	66.7	14	4	M12	22.0	12.7	38.1	33.3	9.5
3/4	26.9	101.6	73.0	14	4	M12	27.5	12.7	44.5	38.1	11.1
1	33.7	120.7	87.3	18	4	M16	34.5	12.7	52.4	47.6	11.1
1 1/4	42.5	133.4	98.4	18	4	M16	43.5	12.7	63.5	55.6	11.1
1 1/2	48.3	139.7	104.8	18	4	M16	49.5	12.7	69.9	61.9	12.7
2	60.3	165.4	127.0	18	4	M16	61.5	15.9	92.9	74.6	12.7
2 1/2	76.1	184.2	146.1	18	8	M16	77.5	15.9	111.9	90.5	15.9
3	88.9	203.2	165.1	18	8	M16	90.5	15.9	130.2	106.4	15.9
4	114.3	228.6	190.5	18	8	M16	116.0	19.1	152.4	133.4	19.0
5	139.7	279.4	235.0	22	8	M20	141.5	22.2	190.5	160.3	19.0
6 1/2	165.1	304.8	260.4	22	12	M20	167.3	22.2	215.9	185.7	19.0
6 5/8	168.3	304.8	260.4	22	12	M20	170.5	22.2	215.9	185.7	19.0
8	219.1	368.3	323.9	22	12	M20	221.5	25.4	279.4	241.3	22.2
10	273.0	431.8	381.0	25	12	M22	276.5	28.6	328.6	298.5	27.0
12	323.9	489.0	438.2	25	16	M22	327.5	31.8	385.8	349.3	28.6

TABLE F

Bossed Screwed Flanges

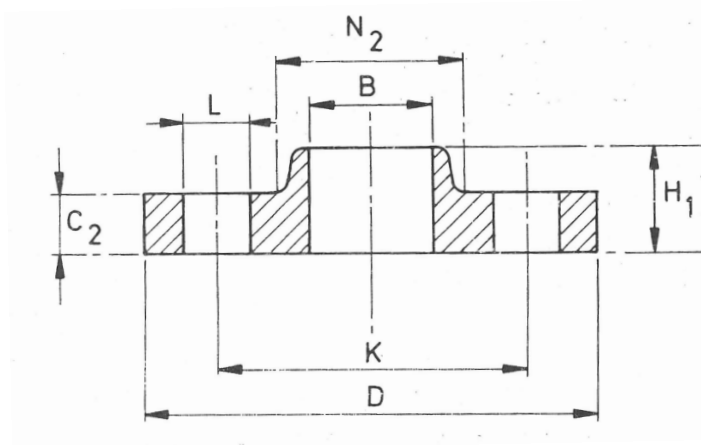

Nominal Size	Pipe OD	Outside Diameter	Bolt Circle Diameter	Bolt Hole Diameter	Bolting		Flange Thickness Min	Boss Diameter	Boss Diameter	Boss Height
	MM	MM	MM	MM	No.	Size (MM)	MM	Large End Max. (MM)	Small End (MM)	MM
1/2	21.3	95.3	66.7	14	4	M12	12.7	38.1	33.3	9.5
3/4	26.9	101.6	73.0	14	4	M12	12.7	44.5	38.1	11.1
1	33.7	120.7	87.3	18	4	M16	12.7	52.4	47.6	11.1
1 1/4	42.5	133.4	98.4	18	4	M16	12.7	63.5	55.6	11.1
1 1/2	48.3	139.7	104.8	18	4	M16	12.7	69.9	61.9	12.7
2	60.3	165.4	127.0	18	4	M16	15.9	92.9	74.6	12.7
2 1/2	76.1	184.2	146.1	18	8	M16	15.9	111.9	90.5	15.9
3	88.9	203.2	165.1	18	8	M16	15.9	130.2	106.4	15.9
4	114.3	228.6	190.5	18	8	M16	19.1	152.4	133.4	19.1
5	139.7	279.4	235.0	22	8	M20	22.2	190.5	160.3	19.1
6	165.1	304.8	260.4	22	12	M20	22.2	215.9	185.7	19.1

TABLE H

Plate Slip-On Flanges

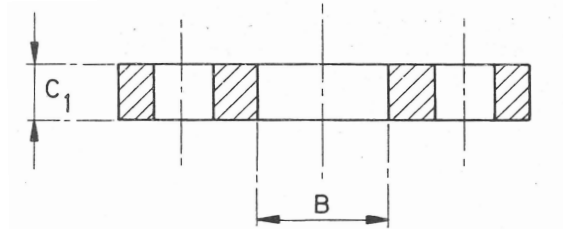

Nominal Size	Pipe OD	Outside Diameter	Bolt Circle Diameter	Bolt Hole Diameter	Bolting		Bore Diameter	Flange Thickness Min
	MM	MM	MM	MM	No.	Size (MM)	MM	MM
1/2	21.3	114.3	82.6	18	4	M16	22.0	12.7
3/4	26.9	114.3	82.6	18	4	M16	27.5	12.7
1	33.7	120.7	87.3	18	4	M16	34.5	14.3
1 1/4	42.5	133.4	98.4	18	4	M16	43.5	17.5
1 1/2	48.3	139.7	104.8	18	4	M16	49.5	17.5
2	60.3	165.1	127.0	18	4	M16	61.5	19.0
2 1/2	76.1	184.1	146.0	18	8	M16	77.5	19.0
3	88.9	203.2	165.1	18	8	M16	90.5	22.2
4	114.3	228.6	190.5	18	8	M20	116.0	25.4
5	139.7	279.4	235.0	22	8	M20	141.5	28.6
6 1/2	165.1	304.8	260.3	22	12	M20	167.3	28.6
6 5/8	168.3	304.8	260.3	22	12	M20	170.5	28.6
8	219.1	368.3	323.9	22	12	M20	221.5	31.8
9	244.5	406.4	355.6	24	12	M20	246.9	34.9
10	273.0	431.8	381.0	24	12	M22	276.5	34.9
12	323.9	489.0	438.2	24	16	M22	327.5	41.3

TABLE H

Plate Blind Flanges

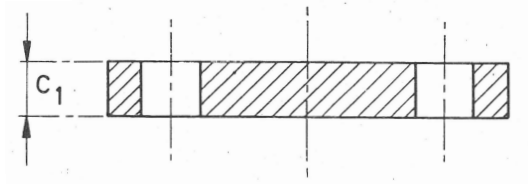

Nominal Size	Pipe OD	Outside Diameter	Bolt Circle Diameter	Bolt Hole Diameter	Bolting		Flange Thickness Min
	MM	MM	MM	MM	No.	Size (MM)	MM
1/2	21.3	114.3	82.6	18	4	M16	12.7
3/4	26.9	114.3	82.6	18	4	M16	12.7
1	33.7	120.7	87.3	18	4	M16	14.3
1 1/4	42.5	133.4	98.4	18	4	M16	17.5
1 1/2	48.3	139.7	104.8	18	4	M16	17.5
2	60.3	165.1	127.0	18	4	M16	19.0
2 1/2	76.1	184.1	146.0	18	8	M16	19.0
3	88.9	203.2	165.1	18	8	M16	22.2
4	114.3	228.6	190.5	18	8	M20	25.4
5	139.7	279.4	235.0	22	8	M20	28.6
6 1/2	165.1	304.8	260.3	22	12	M20	28.6
6 5/8	168.3	304.8	260.3	22	12	M20	28.6
8	219.1	368.3	323.9	22	12	M20	31.8
10	273.0	431.8	381.0	24	12	M22	34.9
12	323.9	489.0	438.2	24	16	M22	41.3

TABLE H

Bossed Slip-On Flanges

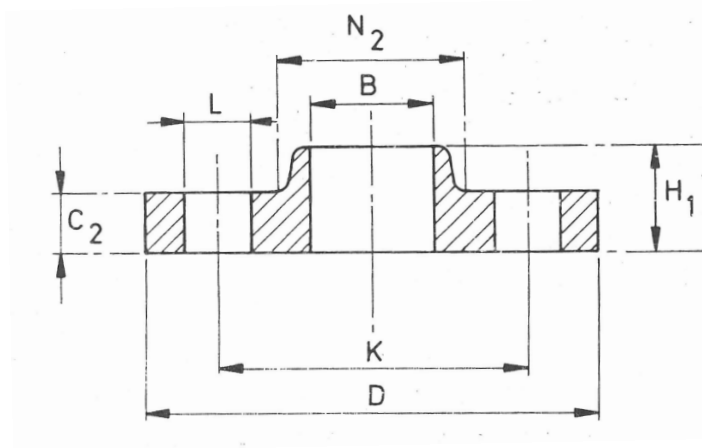

Nominal Size	Pipe OD	Outside Diameter	Bolt Circle Diameter	Bolt Hole Diameter	Bolting		Bore Diameter	Flange Thickness Min	Boss Diameter	Boss Diameter	Boss Height
	MM	MM	MM	MM	No.	Size (MM)	MM	MM	Large End Max. (MM)	Small End (MM)	MM
1/2	21.3	114.3	82.6	18	4	M16	22.0	12.7	38.1	33.3	9.5
3/4	26.9	114.3	82.6	18	4	M16	27.5	12.7	44.5	38.1	11.1
1	33.7	120.7	87.3	18	4	M16	34.5	14.3	52.4	47.6	11.1
1 1/4	42.5	133.4	98.4	18	4	M16	43.5	17.5	63.5	55.6	11.1
1 1/2	48.3	139.7	104.8	18	4	M16	49.5	17.5	69.9	61.9	12.7
2	60.3	165.1	127.0	18	4	M16	61.5	19.0	92.9	74.6	12.7
2 1/2	76.1	184.1	146.0	18	8	M16	77.5	19.0	111.9	90.5	15.9
3	88.9	203.2	165.1	18	8	M16	90.5	22.2	130.2	106.4	15.9
4	114.3	228.6	190.5	18	8	M20	116.0	25.4	152.4	133.4	19.1
5	139.7	279.4	235.0	22	8	M20	141.5	28.6	190.5	160.3	19.1
6 1/2	165.1	304.8	260.3	22	12	M20	167.3	28.6	215.9	185.7	19.1
6 5/8	168.3	304.8	260.3	22	12	M20	170.5	28.6	215.9	185.7	19.0
8	219.1	368.3	323.9	22	12	M20	221.5	31.8	279.4	241.3	22.2
10	273.0	431.8	381.0	25	12	M22	276.5	34.9	328.6	298.5	27.0
12	323.9	489.0	438.2	25	16	M22	327.5	41.3	385.8	349.3	28.6

TABLE H

Bossed Screwed Flanges

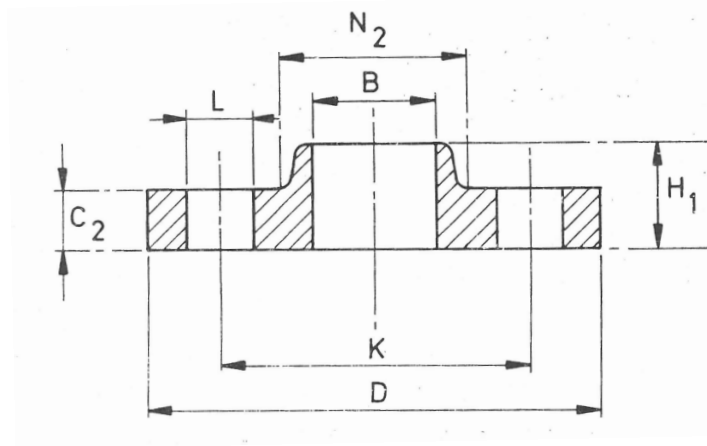

Nominal Size	Pipe OD	Outside Diameter	Bolt Circle Diameter	Bolt Hole Diameter	Bolting		Flange Thickness Min	Boss Diameter	Boss Diameter	Boss Height
	MM	MM	MM	MM	No.	Size (MM)	MM	Large End Max. (MM)	Small End (MM)	MM
1/2	21.3	114.3	82.6	18	4	M16	12.7	38.1	33.3	9.5
3/4	26.9	114.3	82.6	18	4	M16	12.7	44.5	38.1	11.1
1	33.7	120.7	87.3	18	4	M16	14.3	52.4	47.6	11.1
1 1/4	42.5	133.4	98.4	18	4	M16	17.5	63.5	55.6	11.1
1 1/2	48.3	139.7	104.8	18	4	M16	17.5	69.9	61.9	12.7
2	60.3	165.1	127.0	18	4	M16	19.0	92.9	74.6	12.7
2 1/2	76.1	184.1	146.0	18	8	M16	19.0	111.9	90.5	15.9
3	88.9	203.2	165.1	18	8	M16	22.2	130.2	106.4	15.9
4	114.3	228.6	190.5	18	8	M16	25.4	152.4	133.4	19.1

Slip-On Inside Diameters (Bore)

Applies to all tables

NB Size	Approx Diameter of Pipe	Inside Diameter
½"	21.3 mm	22.0 mm
¾"	26.9 mm	27.5 mm
1"	33.7 mm	34.5 mm
1 ¼"	42.5 mm	43.5 mm
1 ½"	48.3 mm	49.5 mm
2"	60.3 mm	61.5 mm
2 ½"	76.1 mm	77.5 mm
3"	88.9 mm	90.5 mm
4"	114.3 mm	116.0 mm
5"	139.7 mm	141.5 mm
6 ½"	165.1 mm	167.3 mm
6 5/8"	168.3 mm	170.5 mm
8"	219.1mm	221.5 mm
10"	273.0 mm	276.5 mm
12"	323.9 mm	327.5 mm
14"	355.6 mm	359.5 mm
16"	406.4 mm	411.0 mm
18"	457.0 mm	462.0 mm
20"	508.0 mm	513.5 mm
24"	610.0 mm	616.5 mm