

# EN 1092-1

Flanges

## ASHBY SCOTT

PIPE SYSTEMS



# TYPE 01

## Plate Flanges PN6

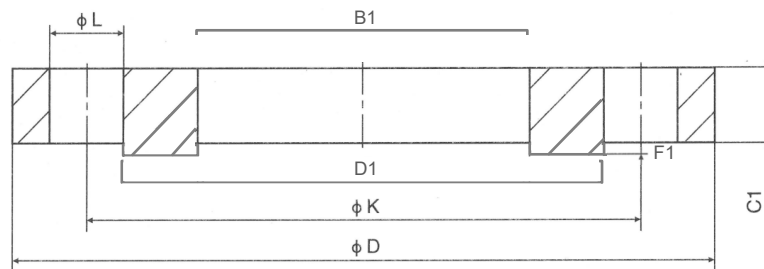

Dimensions are in mm.

DN	FLANGE				DRILLING TEMPLATE			WEIGHT
	B1	D	C1	K	No.	Thread	L	KG
10	18.0	75	12	50	4	M10	11	0.35
15	22.0	80	12	55	4	M10	11	0.41
20	27.5	90	14	65	4	M10	11	0.59
25	34.5	100	14	75	4	M10	11	0.71
32	43.5	120	16	90	4	M12	14	1.16
40	49.5	130	16	100	4	M12	14	1.35
50	61.5	140	16	110	4	M12	14	1.48
65	77.5	160	16	130	4	M12	14	1.86
80	90.5	190	18	150	4	M16	18	2.95
100	116.0	210	18	170	4	M16	18	3.26
125	141.5	240	20	200	8	M16	18	4.31
150	170.5	265	20	225	8	M16	18	4.76
200	221.5	320	22	280	8	M16	18	6.88
250	276.5	375	24	335	12	M16	18	8.92
300	327.5	440	24	395	12	M20	22	11.89
350	359.5	490	26	445	12	M20	22	16.81
400	411.0	540	28	495	16	M20	22	19.80
450	462.0	595	30	550	16	M20	22	24.60
500	513.5	645	30	600	20	M20	22	26.40
600	616.5	755	32	705	20	M24	26	34.80
700	717.0	860	40	810	24	M24	26	73.17
800	818.0	975	44	920	24	M27	30	103.46
900	922.0	1075	48	1020	24	M27	30	124.76
1000	1022.0	1175	52	1120	28	M27	30	169.62
1200	1226.0	1405	60	1340	32	M30	33	267.11
1400	*	1630	72	1560	36	M33	36	*
1600	*	1830	80	1760	40	M33	36	*
1800	*	2045	88	1970	44	M36	39	*
2000	*	2265	96	2180	48	M39	42	*

\* To be specified by the purchaser.

Please note: 10mm available on request.

# TYPE 01

## Plate Flanges PN10

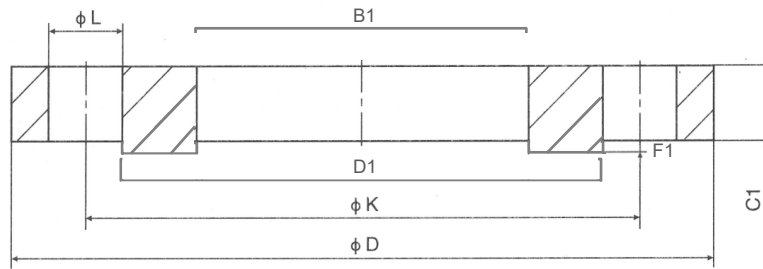

Dimensions are in mm.

DN	FLANGE				DRILLING TEMPLATE			WEIGHT
	B1	D	C1	K	No.	Thread	L	KG
15 - 40	See dimension PN40							
50 - 150	See dimension PN16							
200	221.5	340	24	295	8	M20	22	9.27
250	276.5	395	26	350	12	M20	22	11.80
300	327.5	445	26	400	12	M20	22	13.60
350	359.5	505	30	460	12	M20	22	21.80
400	411.0	565	32	515	16	M20	22	27.50
450	462.0	615	36	565	16	M24	26	33.60
500	513.5	670	38	620	20	M24	26	40.20
600	616.5	780	42	725	20	M24	26	54.50
700	717.0	895	50	840	24	M27	30	73.17
800	818.0	1015	56	950	24	M27	30	103.46
900	922.0	1115	62	1050	24	M30	33	124.76
1000	1022.0	1230	70	1160	28	M30	33	169.62
1200	1226.0	1455	83	1380	32	M33	36	267.11

# TYPE 01

## Plate Flanges PN16

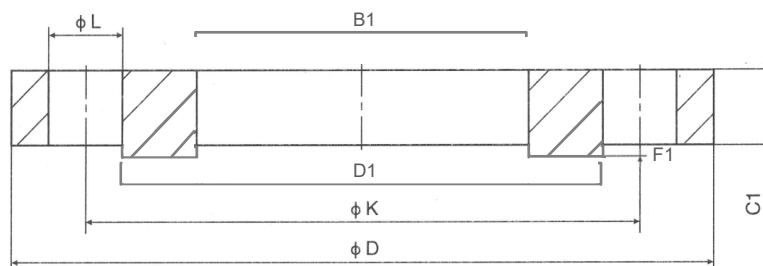

Dimensions in mm.

DN	FLANGE				DRILLING TEMPLATE			WEIGHT
	B1	D	C1	K	No.	Thread	L	KG
15 - 40	See dimension PN40							
50	61.5	165	20	125	4	M16	18	2.73
65	77.5	185	20	145	4 OR 8*	M16	18	3.16
80	90.5	200	20	160	8	M16	18	3.60
100	116.0	220	22	180	8	M16	18	4.39
125	141.5	250	22	210	8	M16	18	5.41
150	170.5	285	24	240	8	M20	22	7.14
200	221.5	340	26	295	12	M20	22	9.73
250	276.5	405	29	355	12	M24	26	14.20
300	327.5	460	32	410	12	M24	26	19.00
350	359.5	520	35	470	16	M24	26	28.20
400	411.0	580	38	525	16	M27	30	35.90
450	462.0	640	42	585	20	M27	30	46.10
500	513.5	715	46	650	20	M30	33	64.00
600	616.5	840	55	770	20	M33	36	82.60
700	717.0	910	63	840	24	M33	36	98.49
800	818.0	1025	74	950	24	M36	39	143.02
900	922.0	1125	82	1050	28	M36	39	172.09
1000	1022.0	1255	90	1170	28	M39	42	246.37
1200	1226.0	1485	98	1390	32	M45	48	352.74

\* Supplied as 4 unless otherwise requested

# TYPE 01

## Plate Flanges PN25

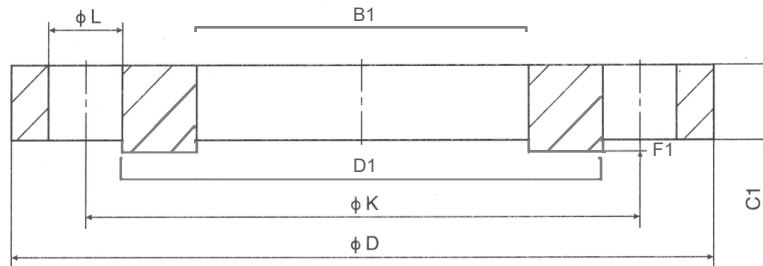

Dimensions are in mm.

DN	FLANGE				DRILLING TEMPLATE			WEIGHT
	B1	D	C1	K	No.	Thread	L	KG
15 - 150	See dimension PN40							
200	221.5	360	32	310	12	M24	26	14.30
250	276.5	425	35	370	12	M27	30	20.10
300	327.5	485	38	430	16	M27	30	26.60
350	359.5	555	42	490	16	M30	33	41.80
400	411.0	620	48	550	16	M33	36	57.60
450	462.0	670	54	600	20	M33	36	69.80
500	513.5	730	58	660	20	M33	36	87.00
600	616.5	845	68	770	20	M36	39	127.00
700	717.0	960	85	875	24	M39	42	175.20
800	818.0	1085	95	990	24	M45	48	269.40

# TYPE 01

## Plate Flanges PN40

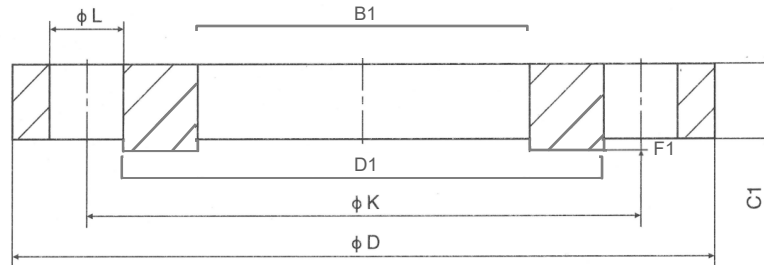

Dimensions are in mm.

DN	FLANGE				DRILLING TEMPLATE			WEIGHT
	B1	D	C1	K	No.	Thread	L	KG
10	18.0	90	14	60	4	M12	14	0.61
15	22.0	95	14	65	4	M12	14	0.67
20	27.5	105	16	75	4	M12	14	0.93
25	34.5	115	16	85	4	M12	14	1.11
32	43.5	140	18	100	4	M16	18	1.82
40	49.5	150	18	110	4	M16	18	2.08
50	61.5	165	20	125	4	M16	18	2.73
65	77.5	185	22	145	8	M16	18	3.48
80	90.5	200	24	160	8	M16	18	4.32
100	116.0	235	26	190	8	M20	22	6.07
125	141.5	270	28	220	8	M24	26	8.19
150	170.5	300	30	250	8	M24	26	10.31
200	221.5	375	36	320	12	M27	30	17.90
250	276.5	450	42	385	12	M30	33	29.30
300	327.5	515	52	450	16	M30	33	45.10
350	359.5	580	58	510	16	M33	36	66.70
400	411.0	660	65	585	16	M36	39	97.10

Please note: 10mm available on request.

# TYPE 05

## Blind Flanges PN6

Dimensions are in mm.

DN	FLANGE			DRILLING TEMPLATE			G Max.	WEIGHT
	D	C4	K	No.	Thread	L	MM	KG
10	75	12	50	4	M10	11	-	0.38
15	80	12	55	4	M10	11	-	0.43
20	90	14	65	4	M10	11	-	0.45
25	100	14	75	4	M10	11	-	0.82
32	120	14	90	4	M12	14	-	1.18
40	130	14	100	4	M12	14	-	1.39
50	140	14	110	4	M12	14	-	1.62
65	160	14	130	4	M12	14	55	2.14
80	190	16	150	4	M16	18	70	3.43
100	210	16	170	4	M16	18	90	4.22
125	240	18	200	8	M16	18	115	6.10
150	265	18	225	8	M16	18	140	7.51
200	320	20	280	8	M16	18	190	12.30
250	375	22	335	12	M16	18	235	18.50
300	440	22	395	12	M20	22	285	25.50
350	490	22	445	12	M20	22	330	31.80
400	540	22	495	16	M20	22	380	38.50
450	595	24	550	16	M20	22	425	51.20
500	645	24	600	20	M20	22	475	60.10
600	755	30	705	20	M24	26	575	103.00
700	860	40	810	24	M24	26	670	178.00
800	975	44	920	24	M27	30	770	252.00
900	1075	48	1020	24	M27	30	860	336.00
1000	1175	52	1120	28	M27	30	960	435.00
1200	1405	60	1340	32	M30	33	1160	717.00
1400	1630	68	1560	36	M33	36	1346	1094.00
1600	1830	76	1760	40	M33	36	1546	1545.00
1800	2045	84	1970	44	M36	39	1746	2131.00
2000	2265	92	2180	48	M39	42	1950	2862.00

Please note: 10mm available on request.

# TYPE 05

## Blind Flanges PN10

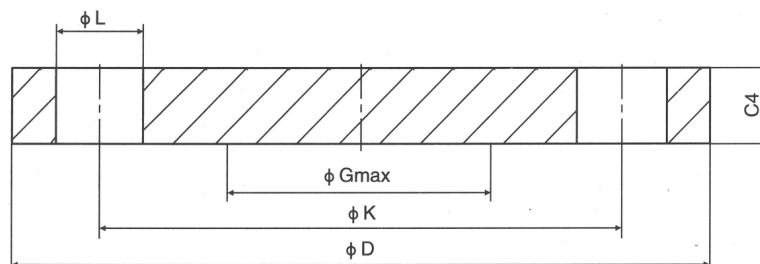

Dimensions are in mm.

DN	FLANGE			DRILLING TEMPLATE			G Max.	WEIGHT
	D	C4	K	No.	Thread	L	MM	KG
15 - 40	See dimension PN40							
50 - 150	See dimension PN16							
200	340	24	295	8	M20	22	190	16.50
250	395	26	350	12	M20	22	235	24.10
300	445	26	400	12	M20	22	285	30.80
350	505	26	460	16	M20	22	330	39.60
400	565	26	515	16	M24	26	380	49.40
450	615	28	656	20	M24	26	425	63.00
500	670	28	620	20	M24	26	475	75.20
600	780	34	725	20	M27	30	575	124.00
700	895	38	840	24	M27	30	670	183.00
800	1015	48	950	24	M30	33	770	297.00
900	1115	50	1050	28	M30	33	860	374.00
1000	1230	54	1160	28	M33	36	960	492.00
1200	1455	66	1380	32	M36	39	1160	842.00



# TYPE 05

## Blind Flanges PN16

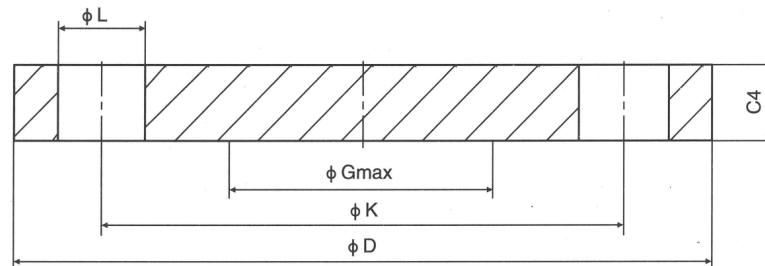

Dimensions are in mm.

DN	FLANGE			DRILLING TEMPLATE			G Max.	WEIGHT
	D	C4	K	No.	Thread	L	MM	KG
15 - 40	See dimension PN40							
50	165	18	125	4	M16	18	-	2.88
65	185	18	145	4 OR 8*	M16	18	55	3.51
80	200	20	160	8	M16	18	70	4.61
100	220	20	180	8	M16	18	90	5.65
125	250	22	210	8	M16	18	115	8.13
150	285	22	240	8	M20	22	140	10.5
200	340	24	295	12	M20	22	190	16.20
250	405	26	355	12	M24	26	235	25.00
300	460	28	410	12	M24	26	285	35.10
350	520	30	470	16	M24	26	330	48.00
400	580	32	525	16	M27	30	380	63.50
450	640	40	585	20	M27	30	425	96.60
500	715	44	650	20	M30	33	475	133.00
600	840	54	770	20	M33	36	575	226.00
700	910	58	840	24	M33	36	670	285.00
800	1025	62	950	24	M36	39	770	388.00
900	1125	64	1050	28	M36	39	860	483.00
1000	1255	68	1170	28	M39	42	960	640.00

\*Supplied as 4 unless otherwise requested.

# TYPE 05

## Blind Flanges PN25

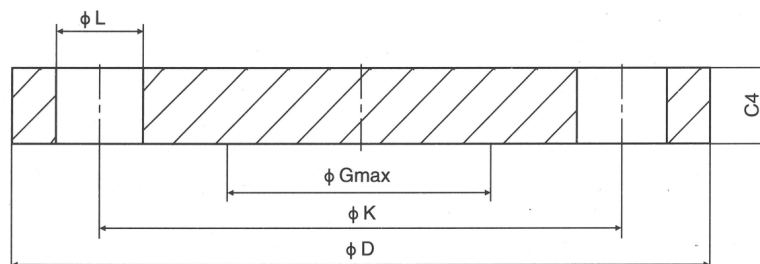

Dimensions are in mm.

DN	FLANGE			DRILLING TEMPLATE			G Max.	WEIGHT
	D	C4	K	No.	Thread	L	MM	KG
15 - 150	See dimension PN40							
200	360	30	310	12	M24	26	190	22.50
250	425	32	370	12	M27	30	235	33.50
300	485	34	430	16	M27	30	285	46.30
350	555	38	490	16	M30	33	330	68.10
400	620	40	550	16	M33	36	380	89.70
450	670	50	600	20	M33	36	425	130.00
500	730	51	660	20	M33	36	475	159.00
600	845	66	770	20	M36	39	575	278.00

# TYPE 05

## Blind Flanges PN40

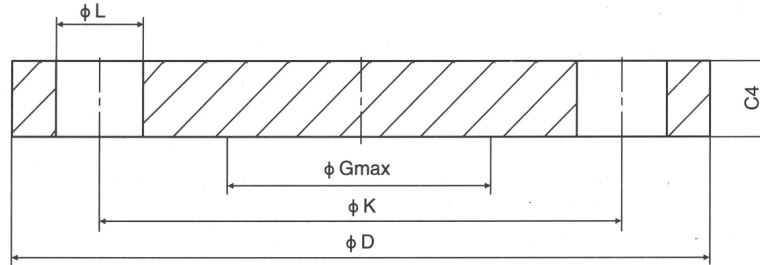

Dimensions are in mm.

DN	FLANGE			DRILLING TEMPLATE			G Max.	WEIGHT
	D	C4	K	No.	Thread	L	MM	KG
10	90	16	60	4	M12	14	-	0.72
15	95	16	65	4	M12	14	-	0.81
20	105	18	75	4	M12	14	-	1.14
25	115	18	85	4	M12	14	-	1.38
32	140	18	100	4	M16	18	-	2.03
40	150	18	110	4	M16	18	-	2.35
50	165	20	125	4	M16	18	-	3.2
65	185	22	145	8	M16	18	55	4.29
80	200	24	160	8	M16	18	70	5.54
100	235	24	190	8	M20	22	90	7.6
125	270	26	220	8	M24	26	115	10.8
150	300	28	250	8	M24	26	140	14.6
200	375	36	320	12	M24	30	190	28.80
250	450	38	385	12	M24	33	235	44.40
300	515	42	450	16	M24	33	285	64.20
350	580	46	510	16	M36	36	330	89.50
400	660	50	585	16	M36	39	380	127.00
450	685	57	610	20	M39	39	425	154.00
500	755	57	670	20	M45	42	475	188.00
600	890	72	795	20	M36	48	575	331.00

Please note: 10mm available on request.

# TYPE 11

## Weld-Neck Flanges PN6

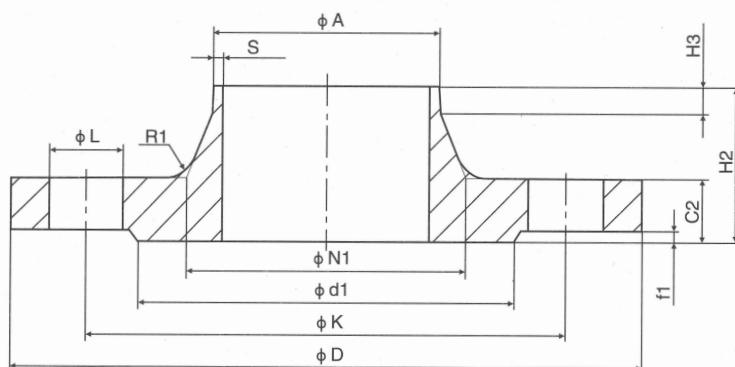

Dimensions are in mm.

DN	A	FLANGE				HUB				FACING		DRILLING TEMPLATE		WEIGHT KG	
		D	C2	K	H2	N1	S	R1	H3	d1	f1	No.	Thread		L
10	17.2	75	12	50	28	26	2.0	4	6	35	2	4	M10	11	0.35
15	21.3	80	12	55	30	30	2.0	4	6	40	2	4	M10	11	0.40
20	26.9	90	14	65	32	38	2.3	4	6	5	2	4	M10	11	0.62
25	33.7	100	14	75	35	42	2.6	4	6	60	2	4	M10	11	0.76
32	42.4	120	14	90	35	55	2.6	6	6	70	2	4	M12	14	1.11
40	48.3	130	14	100	38	62	2.6	6	7	80	3	4	M12	14	1.26
50	60.3	140	14	110	38	74	2.9	6	8	90	3	4	M12	14	1.43
65	76.1	160	14	130	38	88	2.9	6	9	110	3	4	M12	14	1.77
80	88.9	190	16	150	42	102	3.2	8	10	128	3	4	M16	18	2.88
100	114.3	210	16	170	45	130	3.6	8	10	148	3	4	M16	18	3.41
125	139.7	240	18	200	48	155	4.0	8	10	178	3	8	M16	18	4.65
150	168.3	265	18	225	48	184	4.5	10	12	202	3	8	M16	18	5.50
200	219.1	320	20	280	55	236	6.3	10	15	258	3	8	M16	18	8.60
250	273	375	22	335	60	290	6.3	12	15	312	4	12	M16	18	11.70
300	323.9	440	22	395	62	342	7.1	12	15	365	4	12	M20	22	15.30
350	355.6	490	22	445	62	385	7.1	12	15	415	4	12	M20	22	20.30
400	406.4	540	22	495	65	438	7.1	12	15	465	4	16	M20	22	23.10
450	457	595	22	550	65	492	7.1	12	15	520	4	16	M20	22	27.00
500	508	645	24	600	68	538	7.1	12	15	570	4	20	M20	22	30.80
600	610	755	30	705	70	640	7.1	12	16	670	5	20	M24	26	44.00
700	711	860	30	810	76	740	8.0	12	16	775	5	24	M24	26	53.70
800	813	975	30	920	76	842	8.0	12	16	880	5	24	M27	30	64.40
900	914	1075	34	1020	78	942	8.0	12	16	980	5	24	M27	30	79.20
1000	1016	1175	38	1120	82	1045	8.0	16	16	1080	5	28	M27	30	98.60
1200	1219	1405	42	1340	104	1248	8.8	16	20	1295	5	32	M30	33	152.00
1400	1422	1630	56	1560	114	1452	8.8	16	20	1510	5	36	M33	36	246.00
1600	1626	1830	63	1760	119	1655	10.0	16	20	1710	5	40	M33	36	309.00
1800	1829	2045	69	1970	133	1855	11.0	16	20	1920	5	44	M36	39	400.00
2000	2032	2265	74	2180	146	2058	12.5	16	25	2125	5	48	M39	42	516.00

Please note: 10mm available on request.

# TYPE 11

## Weld-Neck Flanges PN10

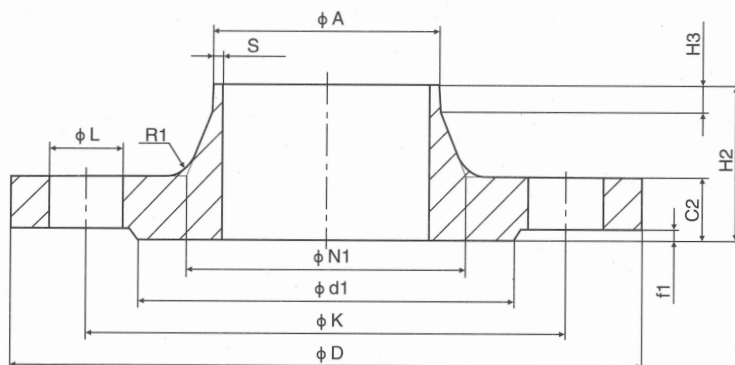

Dimensions are in mm.

DN	A	FLANGE				HUB				FACING		DRILLING TEMPLATE			WEIGHT
		D	C2	K	H2	N1	S	R1	H3	d1	f1	No.	Thread	L	KG
15 - 40	See dimension PN40														
50 - 150	See dimension PN16														
200	219.1	340	24	295	62	234	6.3	10	16	268	3	8	M20	22	11.60
250	273	395	26	350	68	292	6.3	12	16	320	3	12	M20	22	15.80
300	323.9	445	26	400	68	342	7.1	12	16	370	4	12	M20	22	18.30
350	355.6	505	26	460	68	385	7.1	12	16	430	4	16	M20	22	25.30
400	406.4	565	26	515	72	440	7.1	12	16	482	4	16	M24	26	30.60
450	457	615	28	565	72	488	7.1	12	16	532	4	16	M24	26	35.10
500	508	670	28	620	75	542	7.1	12	16	585	4	20	M24	26	40.50
600	610	780	30	725	82	642	8.0	12	18	685	5	20	M27	30	52.90
700	711	895	35	840	85	746	8.8	12	18	800	5	24	M27	30	75.80
800	813	1015	38	950	96	850	8.8	12	18	905	5	24	M30	33	102.00
900	914	1115	38	1050	99	950	12.5	12	20	1005	5	28	M30	33	121.00
1000	1016	1230	44	1160	105	1052	12.5	16	20	1110	5	28	M33	36	161.00
1200	1219	1455	55	1380	132	1256	12.5	16	25	1330	5	32	M36	39	258.00
1400	1422	1675	65	1590	143	1460	14.2	16	25	1535	5	36	M39	42	371.00
1600	1626	1915	75	1820	159	1666	16.0	16	25	1760	5	40	M45	48	547.00
1800	1829	2115	85	2020	175	1868	17.5	16	30	1960	5	44	M45	48	691.00
2000	2032	2325	90	2230	186	2072	17.5	18	30	2170	5	48	M45	48	830.00

# TYPE 11

## Weld-Neck Flanges PN16

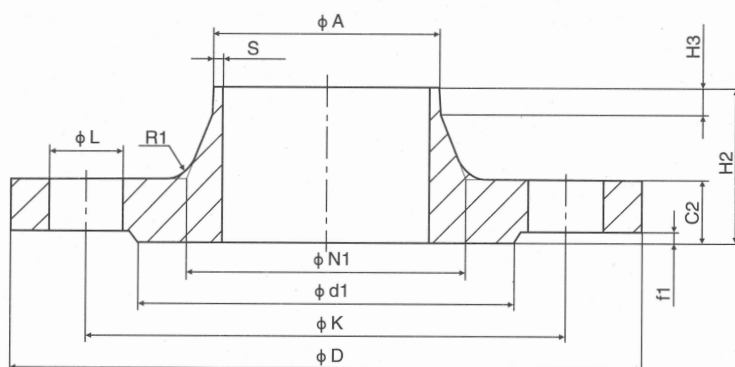

Dimensions are in mm.

DN	A	FLANGE				HUB				FACING		DRILLING TEMPLATE			WEIGHT
		D	C2	K	H2	N1	S	R1	H3	d1	f1	No.	Thread	L	KG
15 - 40	See dimension PN40														
50	60.3	165	18	125	45	74	2.9	6	8	102	3	4	M16	18	2.53
65	76.1	185	18	145	45	92	2.9	6	10	122	3	4 OR 8	M16	18	3.03
80	88.9	200	20	160	50	105	3.2	6	10	138	3	8	M16	18	3.92
100	114.3	220	20	180	52	131	3.6	8	12	158	3	8	M16	18	4.62
125	139.7	250	22	210	55	156	4.0	8	12	188	3	8	M16	18	6.30
150	168.3	285	22	240	55	184	4.5	10	12	212	3	8	M20	22	7.81
200	219.1	340	24	295	62	235	6.3	10	16	268	3	12	M20	22	11.50
250	273	405	26	355	70	292	6.3	12	16	320	3	12	M24	26	16.70
300	323.9	460	28	410	78	344	7.1	12	16	378	4	12	M24	26	22.10
350	355.6	520	30	470	82	390	8.0	12	16	438	4	16	M24	26	32.80
400	406.4	580	32	525	85	445	8.0	12	16	490	4	16	M27	30	41.10
450	457	640	34	585	83	490	8.0	12	16	550	4	20	M27	30	48.50
500	508	715	36	650	84	548	8.0	12	16	610	4	20	M30	33	63.40
600	610	840	40	770	88	670	10.0	12	18	725	5	20	M33	36	96.00
700	711	910	40	840	104	755	10.0	12	18	795	5	24	M33	36	96.50
800	813	1025	41	950	108	855	12.5	12	20	900	5	24	M36	39	122.00
900	914	1125	48	1050	118	955	12.5	12	20	1000	5	28	M36	39	155.00
1000	1016	1255	59	1170	137	1058	12.5	16	22	1115	5	28	M39	42	233.00
1200	1219	1485	78	1390	160	1262	14.2	16	30	1330	5	32	M45	48	390.00
1400	1422	1685	84	1590	177	1465	16.0	16	30	1530	5	36	M45	48	495.00
1600	1626	1930	102	1820	204	1668	17.5	16	35	1750	5	40	M52	56	760.00
1800	1829	2130	110	2020	218	1870	20.0	16	35	1950	5	44	M52	56	929.00
2000	2032	2345	124	2230	238	2072	22.0	16	40	2150	5	48	M56	62	1185.00

# TYPE 11

## Weld-Neck Flanges PN16

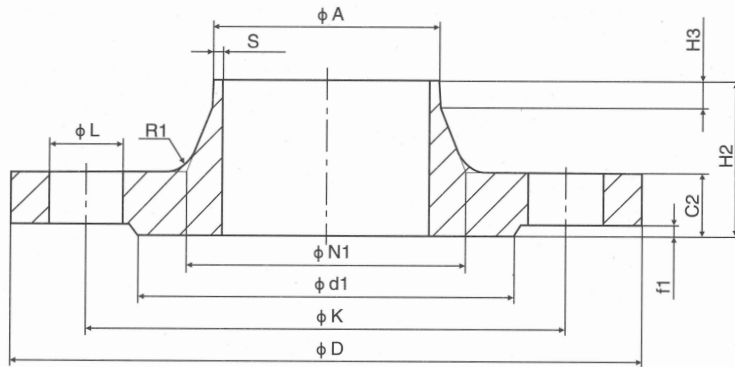

Dimensions are in mm.

DN	A	FLANGE				HUB				FACING		DRILLING TEMPLATE			WEIGHT
		D	C2	K	H2	N1	S	R1	H3	d1	f1	No.	Thread	L	KG
15 - 150	See dimension PN40														
200	219.1	360	30	310	80	244	6.3	10	16	278	3	12	M24	26	17.10
250	273	425	32	370	88	298	7.1	12	18	335	3	12	M27	30	24.30
300	323.9	485	34	430	92	352	8.0	12	18	395	4	16	M27	30	31.80
350	355.6	555	38	490	100	398	8.0	12	20	450	4	16	M30	33	48.80
400	406.4	620	40	550	110	452	8.8	12	20	505	4	16	M33	36	63.30
450	457	670	46	600	110	500	8.8	12	20	555	4	20	M33	36	76.00
500	508	730	48	660	125	558	10.0	12	20	615	4	20	M33	36	97.00
600	610	845	48	770	125	660	11.0	12	20	720	5	20	M36	39	121.00
700	711	960	50	875	129	760	14.2	12	20	820	5	24	M39	42	155.00
800	813	1085	53	990	138	864	16.0	12	22	930	5	24	M45	48	205.00
900	914	1185	57	1090	148	968	17.5	12	24	1030	5	28	M45	48	249.00
1000	1016	1320	63	1210	160	1070	20.0	16	24	1140	5	28	M52	56	338.00

# TYPE 11

## Weld-Neck Flanges PN40

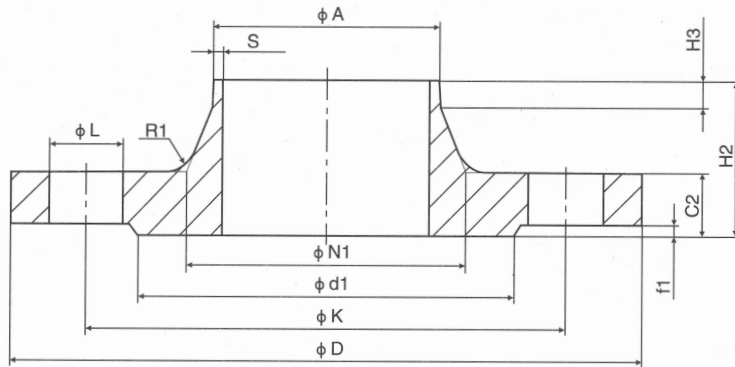

Dimensions are in mm.

DN	A	FLANGE				HUB				FACING		DRILLING TEMPLATE			WEIGHT KG
		D	C2	K	H2	N1	S	R1	H3	d1	f1	No.	Thread	L	
10	17.2	90	16	60	35	28	2.0	4	6	40	2	4	M12	14	0.67
15	21.3	95	16	65	38	32	2.0	4	6	45	2	4	M12	14	0.76
20	26.9	105	18	75	40	40	2.3	4	6	58	2	4	M12	14	1.09
25	33.7	115	18	85	40	46	2.6	4	6	68	2	4	M12	14	13.00
32	42.4	140	18	100	42	56	2.6	6	6	78	2	4	M16	18	1.91
40	48.3	150	18	110	45	64	2.6	6	7	88	3	4	M16	18	2.15
50	60.3	165	20	125	48	75	2.9	6	8	102	3	4	M16	18	2.85
65	76.1	185	22	145	52	90	2.9	6	10	122	3	8	M16	18	3.68
80	88.9	200	24	160	58	105	3.2	8	12	138	3	8	M16	18	4.78
100	114.3	235	24	190	65	134	3.6	8	12	162	3	8	M20	22	6.46
125	139.7	270	26	220	68	162	4.0	8	12	188	3	8	M24	26	8.86
150	168.3	300	28	250	75	192	4.5	10	12	218	3	8	M24	26	11.70
200	219.1	375	34	320	88	244	6.3	10	16	285	3	12	M27	30	21.00
250	273	450	38	385	105	306	7.1	12	18	345	3	12	M30	33	34.20
300	323.9	515	42	450	115	362	8.0	12	18	400	4	16	M30	33	47.60
350	355.6	580	46	510	125	408	8.8	12	20	465	4	16	M33	36	69.30
400	406.4	660	50	585	135	462	11.0	12	20	535	4	16	M36	39	98.00
450	457	685	57	610	135	500	12.5	12	20	560	4	20	M36	39	105.00
500	508	755	57	670	140	562	14.2	12	20	615	4	20	M39	42	130.00
600	610	890	72	795	150	666	16.0	12	20	735	5	20	M45	48	209.00

Please note: 10mm available on request.



# TYPE 12

## Bossed Slip-On Flanges PN6

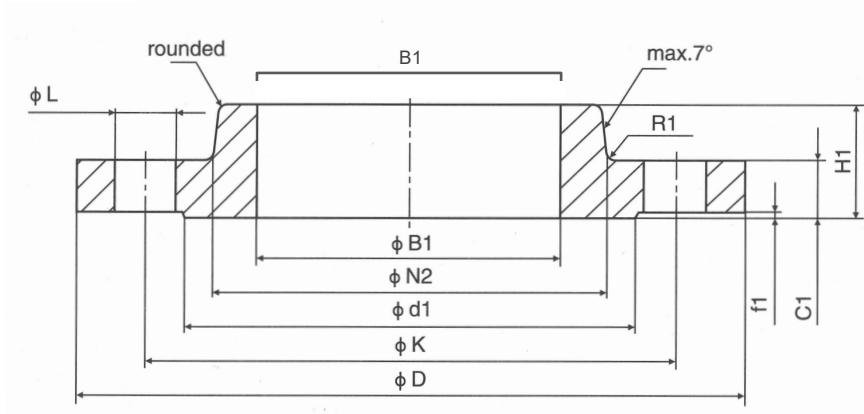

Dimensions are in mm.

DN	FLANGE					HUB		FACING		DRILLING TEMPLATE			WEIGHT
	D	B1	C2	K	H1	N2	R1	d1	f1	No.	Thread	L	KG
10	75	18.0	12	50	20	25	4	35	2	4	M10	11	0.32
15	80	22.0	12	55	20	30	4	40	2	4	M10	11	0.37
20	90	27.5	14	65	24	40	4	50	2	4	M10	11	0.58
25	100	34.5	14	75	24	50	4	60	2	4	M10	11	0.72
32	120	43.5	14	90	26	60	6	70	2	4	M12	14	1.04
40	130	49.5	14	100	26	70	6	80	3	4	M12	14	1.20
50	140	61.5	14	110	28	80	6	110	3	4	M12	14	1.34
65	160	77.5	14	130	32	100	6	128	3	4	M16	18	1.83
80	190	90.5	16	150	34	110	8	148	3	4	M16	18	2.75
100	210	116.0	16	170	40	130	8	178	3	4	M16	18	3.01
125	240	141.5	18	200	44	160	8	202	3	8	M16	18	4.30
150	265	170.5	18	225	44	185	10	258	3	8	M16	18	4.63
200	320	221.5	20	280	44	240	10	312	3	8	M16	18	6.97
250	375	276.5	22	335	44	295	12	365	3	12	M16	18	9.13
300	440	327.5	22	395	44	355	12	440	4	12	M20	22	12.40

Please note: 10mm available on request.

# TYPE 12

## Bossed Slip-On Flanges PN10

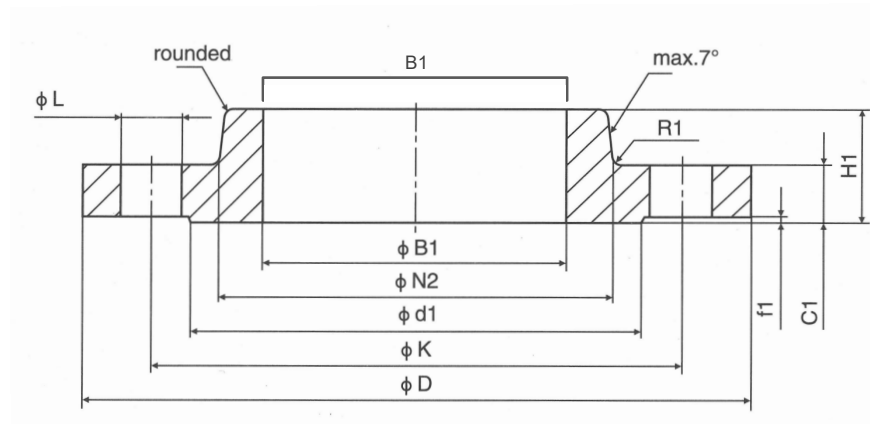

Dimensions are in mm.

DN	FLANGE					HUB		FACING		DRILLING TEMPLATE			WEIGHT
	D	B1	C2	K	H1	N2	R1	d1	f1	No.	Thread	L	KG
15 - 40	See dimension PN40												
50 - 150	See dimension PN16												
200	340	221.5	24	295	44	246	10	268	3	8	M20	22	10.10
250	395	276.5	26	350	46	298	12	320	3	12	M20	22	12.80
300	445	327.5	26	400	46	350	12	370	4	12	M20	22	14.50
350	505	359.5	26	460	53	400	12	430	4	16	M20	22	22.70
400	565	411.0	26	515	57	456	12	482	4	16	M24	26	28.00
450	615	462.0	28	565	63	502	12	532	4	20	M24	26	32.30
500	670	513.5	28	620	67	559	12	585	4	20	M24	26	38.70
600	780	613.5	30	725	75	658	12	685	5	20	M27	30	48.90

# TYPE 12

## Bossed Slip-On Flanges PN16

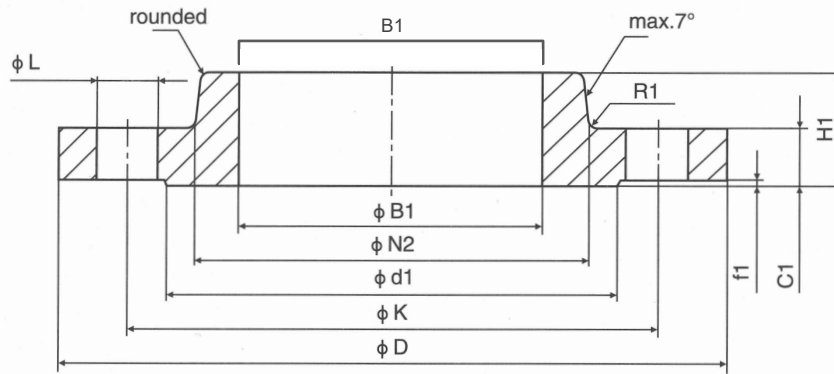

Dimensions are in mm.

DN	FLANGE					HUB		FACING		DRILLING TEMPLATE			WEIGHT
	D	B1	C2	K	H1	N2	R1	d1	f1	No.	Thread	L	KG
15 - 40	See dimension PN40												
50	165	61.5	18	125	28	84	6	102	3	4	M16	18	2.39
65	185	77.5	18	145	32	104	6	122	3	4 OR 8*	M16	18	2.97
80	200	90.5	20	160	34	118	6	138	3	8	M16	18	3.78
100	220	116.0	20	180	40	140	8	158	3	8	M16	18	4.38
125	250	141.5	22	210	44	168	8	188	3	8	M16	18	6.07
150	285	170.5	22	240	44	195	10	212	3	8	M20	22	7.24
200	340	221.5	24	295	44	246	10	268	3	12	M20	22	9.80
250	405	276.5	26	355	46	298	12	320	3	12	M24	26	13.60
300	460	327.5	28	410	46	350	12	378	4	12	M24	26	17.20
350	520	359.0	30	470	57	400	12	438	4	16	M24	26	27.90
400	580	411.0	32	525	63	456	12	490	4	16	M27	30	35.70
450	640	462.0	34	585	68	502	12	550	4	20	M27	30	45.00
500	715	513.5	36	650	73	559	12	610	4	20	M30	33	60.40
600	840	616.5	40	770	83	658	12	725	5	20	M33	36	94.00
700	910	717.0	40	840	83	760	12	795	5	24	M33	36	124.60
800	1025	818.0	41	950	90	864	12	900	5	24	M36	39	180.40
900	1125	929.0	48	1050	94	968	12	1000	5	28	M36	39	210.00
1000	1255	1022.0	59	1170	100	1072	16	1115	5	28	M39	42	362.00

\*Supplied as 4 unless otherwise requested.

# TYPE 12

## Bossed Slip-On Flanges PN25

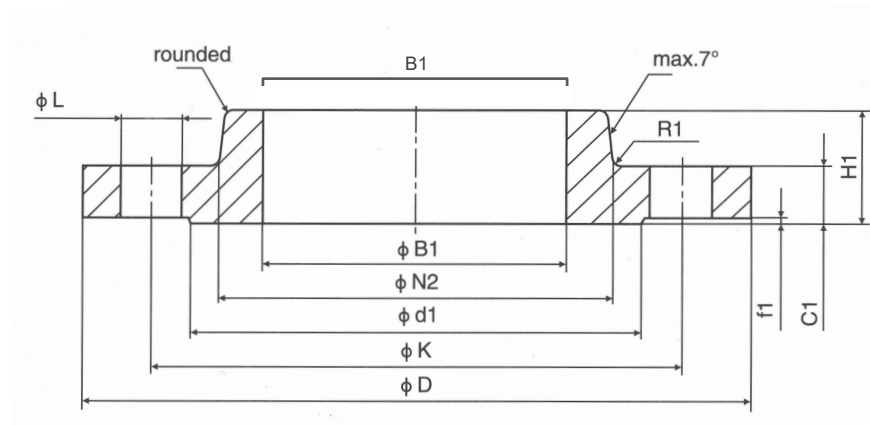

Dimensions are in mm.

DN	FLANGE					HUB		FACING		DRILLING TEMPLATE			WEIGHT
	D	B1	C2	K	H1	N2	R1	d1	f1	No.	Thread	L	KG
15 - 150	See dimension PN40												
200	360	221.5	30	310	52	256	10	278	3	12	M24	26	14.90
250	425	276.5	32	370	60	310	12	335	3	12	M27	30	20.90
300	485	327.5	34	430	67	364	12	395	4	16	M27	30	27.30
350	555	359.0	38	490	72	418	12	450	4	16	M30	33	45.10
400	620	411.0	40	550	78	472	12	505	4	16	M33	36	57.70
450	670	462.0	46	600	84	520	12	555	4	20	M33	36	69.60
500	730	513.5	48	660	90	580	12	615	4	20	M33	36	87.00
600	845	616.5	48	770	100	684	12	720	5	20	M36	39	111.00

# TYPE 12

## Bossed Slip-On Flanges PN40

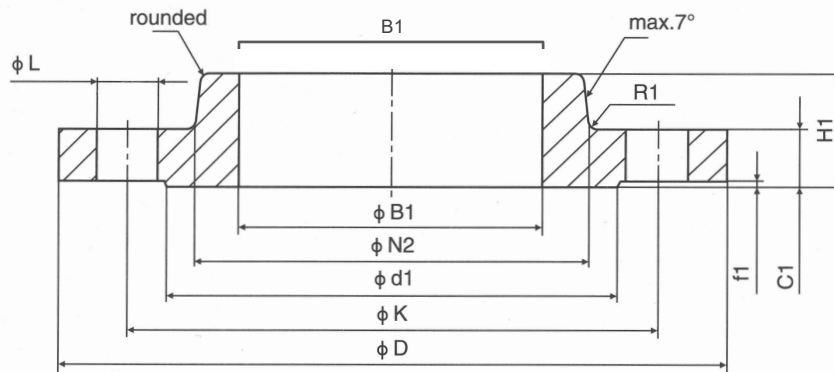

Dimensions are in mm.

DN	FLANGE					HUB		FACING		DRILLING TEMPLATE			WEIGHT
	D	B1	C2	K	H1	N2	R1	d1	f1	No.	Thread	L	KG
10	90	18.0	16	60	22	30	4	40	2	4	M12	14	0.64
15	95	22.0	16	65	22	35	4	45	2	4	M12	14	0.72
20	105	27.5	18	75	26	45	4	58	2	4	M12	14	1.04
25	115	34.5	18	85	28	52	4	68	2	4	M12	14	1.25
32	140	43.5	18	100	30	60	6	78	2	4	M16	18	1.81
40	150	49.5	18	110	32	70	6	88	3	4	M16	18	2.06
50	165	61.5	20	125	34	84	6	102	3	4	M16	18	2.74
65	185	77.5	22	145	38	104	6	122	3	8	M16	18	3.65
80	200	90.5	24	160	40	118	6	138	3	8	M16	18	4.59
100	235	116.0	24	190	44	145	8	162	3	8	M20	22	6.10
125	270	141.5	26	220	48	170	8	188	3	8	M24	26	8.22
150	300	170.5	28	250	52	200	10	218	3	8	M24	26	10.60
200	375	221.5	34	320	52	260	10	285	3	12	M27	30	18.30
250	450	276.5	38	385	60	312	12	345	3	12	M30	33	28.30
300	515	327.5	42	450	67	380	12	410	4	16	M30	33	40.40
350	580	359.0	46	510	72	424	12	465	4	16	M33	36	58.80
400	660	411.0	50	585	78	478	12	535	4	16	M36	39	82.10
450	685	462.0	57	610	84	522	12	560	4	20	M36	39	86.20
500	755	513.5	57	670	90	576	12	615	4	20	M39	42	105.00
600	890	616.5	72	795	100	686	12	435	5	20	M45	48	172.00

Please note: 10mm available on request.

# TYPE 13

## Screwed Flanges PN6

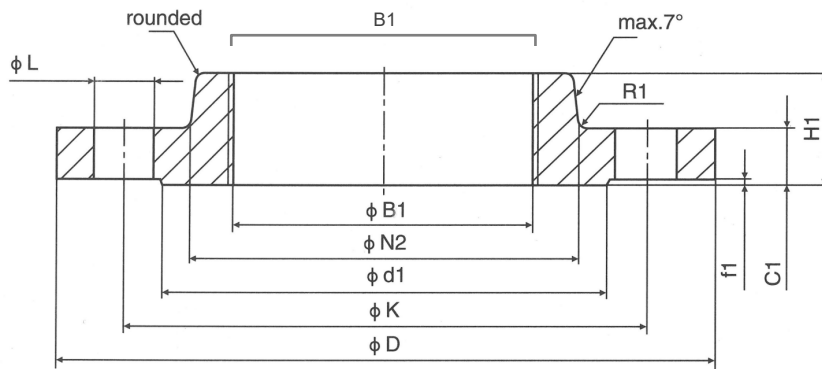

Dimensions are in mm.

DN	FLANGE					HUB		FACING		DRILLING TEMPLATE			WEIGHT
	PIPE	D	C2	K	H1	N2	R1	d1	f1	No.	Thread	L	KG
10	3/8"	75	12	50	20	25	4	35	2	4	M10	11	0.32
15	1/2"	80	12	55	20	30	4	40	2	4	M10	11	0.37
20	3/4"	90	14	65	24	40	4	50	2	4	M10	11	0.58
25	1"	100	14	75	24	50	4	60	2	4	M10	11	0.72
32	1 1/4"	120	14	90	26	60	6	70	2	4	M12	14	1.04
40	1 1/2"	130	14	100	26	70	6	80	3	4	M12	14	1.20
50	2"	140	14	110	28	80	6	90	3	4	M12	14	1.34
65	2 1/2"	160	14	130	28	100	6	110	3	4	M16	18	1.83
80	3"	190	16	150	32	110	6	128	3	4	M16	18	2.75
100	4"	210	16	170	34	130	8	148	3	8	M16	18	3.01
125	5"	240	18	200	40	160	8	178	3	8	M16	18	4.30
150	6"	265	18	225	44	185	10	202	3	8	M16	18	4.63
200	8"	320	20	280	44	240	10	258	3	12	M16	18	6.97
250	10"	375	22	335	44	295	12	312	3	12	M16	18	9.13
300	12"	440	22	395	44	355	12	365	4	12	M20	22	12.40

Please note: 10mm available on request.

# TYPE 13

## Screwed Flanges PN10

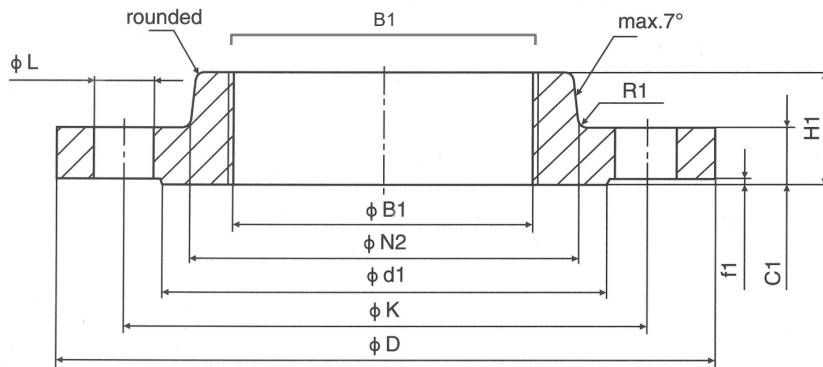

Dimensions are in mm.

DN	FLANGE					HUB		FACING		DRILLING TEMPLATE			WEIGHT
	PIPE	D	C2	K	H1	N2	R1	d1	f1	No.	Thread	L	KG
15 - 40	See dimension PN40												
50 - 150	See dimension PN16												
200	8"	340	24	395	44	246	10	268	3	8	M20	22	10.10
250	10"	395	26	350	46	298	12	320	3	12	M20	22	12.80
300	12"	445	26	400	46	350	12	370	4	12	M20	22	14.50
350	14"	505	26	460	53	400	12	430	4	16	M20	22	22.70
400	16"	565	26	515	57	456	12	482	4	16	M24	26	28.00
450	18"	615	28	565	63	502	12	532	4	20	M24	26	32.30
500	20"	670	28	620	57	559	12	585	4	20	M24	26	38.70
600	24"	780	30	725	75	658	12	685	5	20	M27	30	48.90

# TYPE 13

## Screwed Flanges PN16

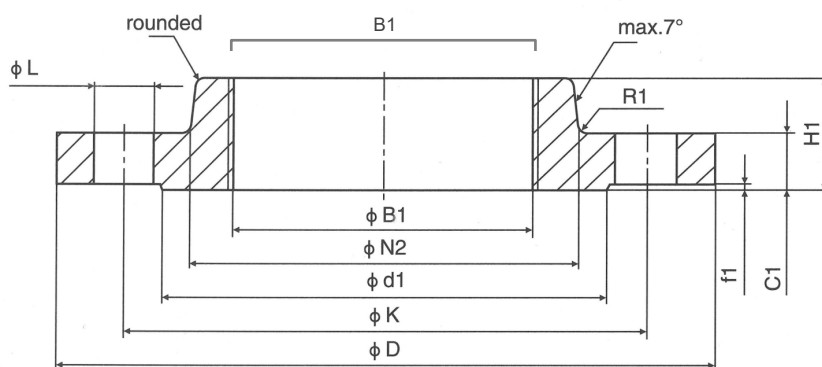

Dimensions are in mm.

DN	FLANGE					HUB		FACING		DRILLING TEMPLATE			WEIGHT
	PIPE	D	C2	K	H1	N2	R1	d1	f1	No.	Thread	L	KG
15 - 40	See dimension PN40												
50	2"	165	18	125	28	80	6	102	3	4	M16	14	2.39
65	2 1/2"	185	18	145	28	100	6	122	3	4 OR 8	M16	18	2.97
80	3"	200	20	160	32	110	6	138	3	8	M16	18	3.78
100	4"	220	20	180	34	130	8	158	3	8	M16	18	4.38
125	5"	250	22	210	40	160	8	188	3	8	M16	18	6.07
150	6"	285	22	240	44	185	10	212	3	8	M20	22	7.24
200	8"	340	24	295	44	246	10	268	3	12	M20	22	9.80
250	10"	405	26	355	46	298	12	320	3	12	M24	26	13.60
300	12"	460	28	410	46	350	12	378	4	12	M24	26	17.20
350	14"	520	30	470	53	400	12	438	4	16	M24	26	27.90
400	16"	580	32	525	57	456	12	490	4	16	M27	30	35.70
450	18"	640	34	585	63	502	12	550	4	20	M27	30	45.00
500	20"	715	36	650	57	559	12	610	4	20	M30	33	60.40
600	24"	840	40	770	75	658	12	725	5	20	M33	36	94.00
700	28"	910	40	840	83	760	12	795	5	24	M33	36	*
800	32"	1025	41	950	90	864	12	900	5	24	M36	39	*
900	36"	1125	48	1050	94	968	12	1000	5	28	M36	39	*
1000	40"	1255	59	1170	100	1072	16	1115	5	28	M39	42	*

\* To be specified by the purchaser



# TYPE 13

## Screwed Flanges PN25

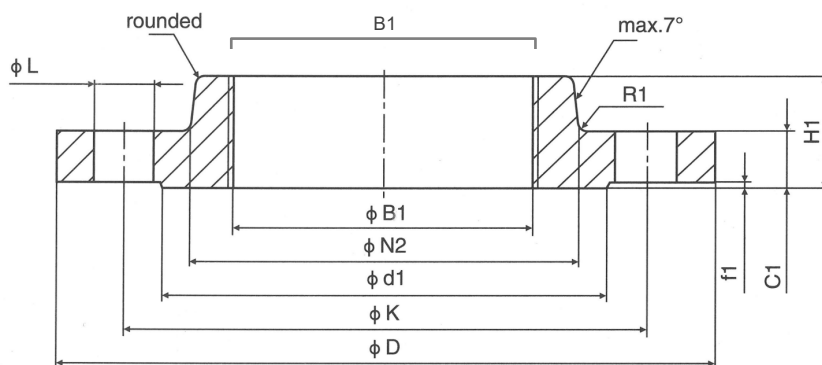

Dimensions are in mm.

DN	FLANGE					HUB		FACING		DRILLING TEMPLATE			WEIGHT
	PIPE	D	C2	K	H1	N2	R1	d1	f1	No.	Thread	L	KG
15 - 150	See dimension PN40												
200	8"	360	30	310	52	256	10	278	3	12	M24	26	14.90
250	10"	425	32	370	60	310	12	335	3	12	M27	30	20.90
300	12"	485	34	430	67	364	12	395	4	16	M27	30	27.30
350	14"	520	38	490	72	418	12	450	4	16	M30	33	45.10
400	16"	555	40	550	78	472	12	505	4	16	M33	36	57.70
450	18"	620	46	600	84	520	12	555	4	20	M33	36	69.60
500	20"	670	48	660	90	580	12	615	4	20	M33	36	87.00
600	24"	730	48	770	100	684	12	720	5	20	M36	39	111.00

# TYPE 13

## Screwed Flanges PN40

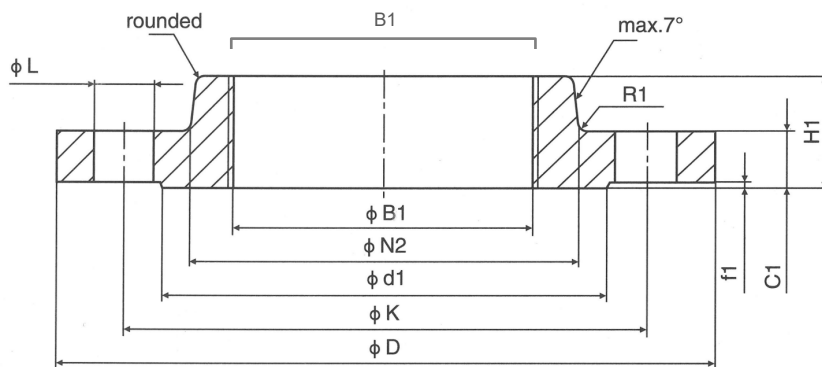

Dimensions are in mm.

DN	FLANGE					HUB		FACING		DRILLING TEMPLATE			WEIGHT
	PIPE	D	C2	K	H1	N2	R1	d1	f1	No.	Thread	L	KG
10	3/8"	90	16	60	22	30	4	40	2	4	M12	14	0.65
15	1/2"	95	16	65	22	35	4	45	2	4	M12	14	0.72
20	3/4"	105	18	75	26	45	4	58	2	4	M12	14	1.04
25	1"	115	18	85	28	52	4	68	2	4	M12	14	1.25
32	1 1/4"	140	18	100	30	60	6	78	2	4	M16	18	1.81
40	1 1/2"	150	18	110	32	70	6	88	3	4	M16	18	2.06
50	2"	165	20	125	34	84	6	102	3	4	M16	18	2.74
65	2 1/2"	185	22	145	38	104	6	122	3	8	M16	18	3.65
80	3"	200	24	160	40	118	8	138	3	8	M16	18	4.59
100	4"	235	24	190	44	145	8	162	3	8	M20	22	6.10
125	5"	270	26	220	48	170	8	188	3	8	M24	26	8.22
150	6"	300	28	250	52	200	10	218	3	8	M24	26	10.60
200	8"	375	34	320	52	260	10	285	3	12	M27	30	18.30
250	10"	450	38	385	60	312	12	345	3	12	M30	33	28.30
300	12"	515	42	450	67	380	12	410	4	16	M30	33	40.40
350	14"	580	46	510	72	424	12	465	4	16	M33	36	58.80
400	16"	660	50	585	78	478	12	535	4	16	M36	39	82.10
450	18"	685	57	610	84	522	12	560	4	20	M36	39	86.20
500	20"	755	57	670	90	576	12	615	4	20	M39	42	105.00
600	24"	890	72	795	100	686	12	735	5	20	M45	48	172.00

Please note: 10mm available on request.